

PCI Membranes

Ultrafiltration Modules Parallel Flow Arrangement



C10 Series

The C10 module, offers the user an economic tubular module which can be fitted with a wide range of proven nanofiltration and ultrafiltration membranes.

The module, has been developed to improve the competitiveness of tubular membrane plants, especially at larger capacities. It can be operated at 12 bar at 20°C.



Membrane cleaning can be done mechanically with the use of foam balls and chemically using established clean-in-place technique at extended frequencies, typically 4 times a year.

SIMPLE MANIFOLD CONNECTIONS

Easy plant maintenance, reduced remembraining time.

ABS CONSTRUCTION

Lightweight, robust.

MODULAR DESIGN

Quick and easy plant construction.

TUBULAR MODULE

No prefiltration required.

Dimensions			
Length (m)	3.66	1.83	0.92
Membrane Area (m ²)	10.5	5.2	2.6

Connection	
Permeate	End Cap Dependent

Additional Details	
Operating Pressure	Up to 12 bar max
Operating Temperature	Up to 30°C
Shroud Material	ABS
Membrane Type	A range of UF and NF membranes
pH Range	Membrane specific

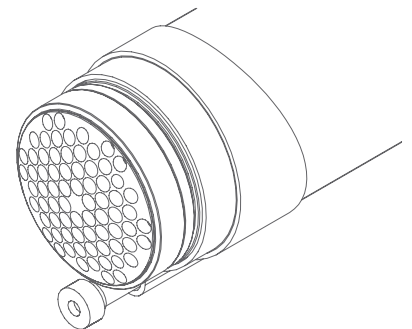
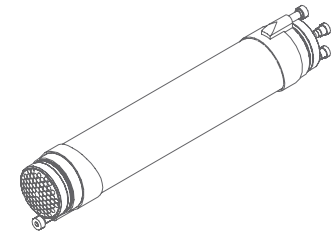
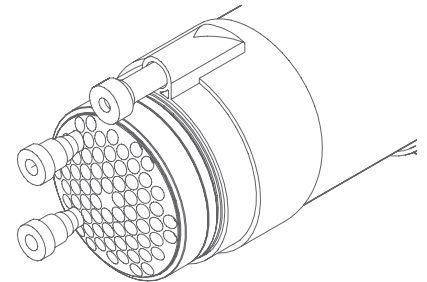
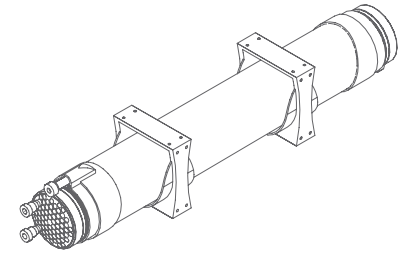

CASE STUDY HISTORY

- The Fyne Process
- Solution for rural water supplies with difficult sources (Achnasheen)
- Solution for rural water supplies with difficult sources (Out Skerries)