

Single Tube Tester

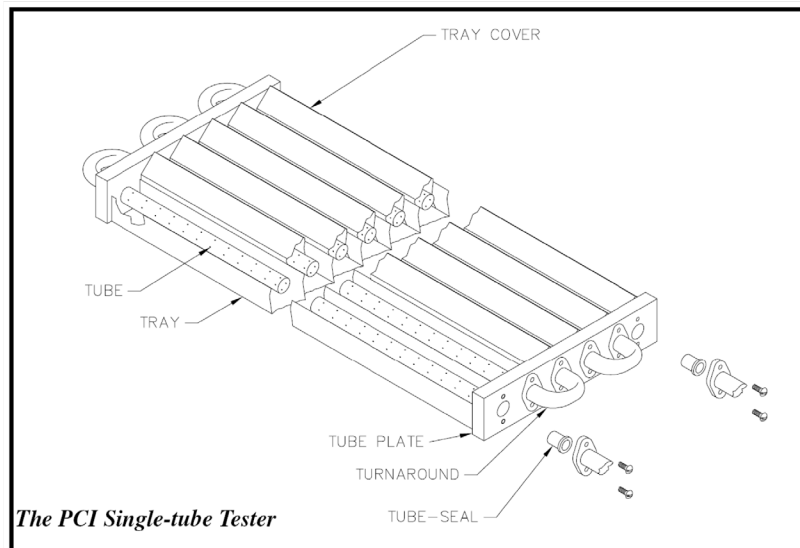

Description

The PCI Single Tube Tester is designed for an economical and quick evaluation of membrane types, process separation and concentration tests at laboratory scale prior to more detailed test work. It may be fitted with samples of any PCI's wide range of tubular reverse osmosis, nanofiltration, ultrafiltration and microfiltration membranes.

Constructed of 316 stainless steel, the Single Tube Tester is designed to be fitted to any PCI's membrane filtration pilot unit, as termination points are available to allow easy connection by flexible or welded couplings to other pilot units.

Up to three membrane types can be fitted at the same time and each has its own permeate collection channel so that testing under identical conditions of feed composition and temperature can be carried out. The Single Tube Tester is available with a length of 1.2m and is thus able to accept the whole range of PCI's membranes; standard and experimental, without any modification. Packs containing six membranes of one type are available from PCI for test purposes.

PCI can make recommendations for experimental operating conditions and test programmes as these can vary greatly depending on membrane type, feed fluid characteristic, experimental objectives and so on.

It is recommended that not more than three types of membranes (2 off each) are installed per test.

2020 11 11 DS

Installation

Membranes should not be grouped together but installed in the following way:

For membrane X, Y, Z:

Tester inlet X – Y – Z – Z – Y – X Tester outlet

For membrane X, Y only:

Tester inlet X – Y – X – Y – X – Y Tester outlet

Operation

There are only 2 options: either total recycle or concentration only recycle can be carried out. Temperature should be at the temperature at which the fluid under test is usually available. Pressure can be varied but for initial testing, the minimal inlet pressure to the tester is recommended.

The permeate flow from each tester outlet should be measured individually and samples taken for analysis at the beginning and end of run.

Connections

Feed inlet: 3/4" OD hose

Permeate outlet: 1/2" OD hose

Corporate Office

PCI Membranes
Unit 11, Fulcrum 2, Solent Way, Whiteley, Fareham,
Hampshire, PO15 7FN, United Kingdom

Phone

+ 44 1489 563 470

Email: pcimembranes@filtrationgroup.com

Online

Website: www.pcimembranes.com

www.filtrationgroup.com